

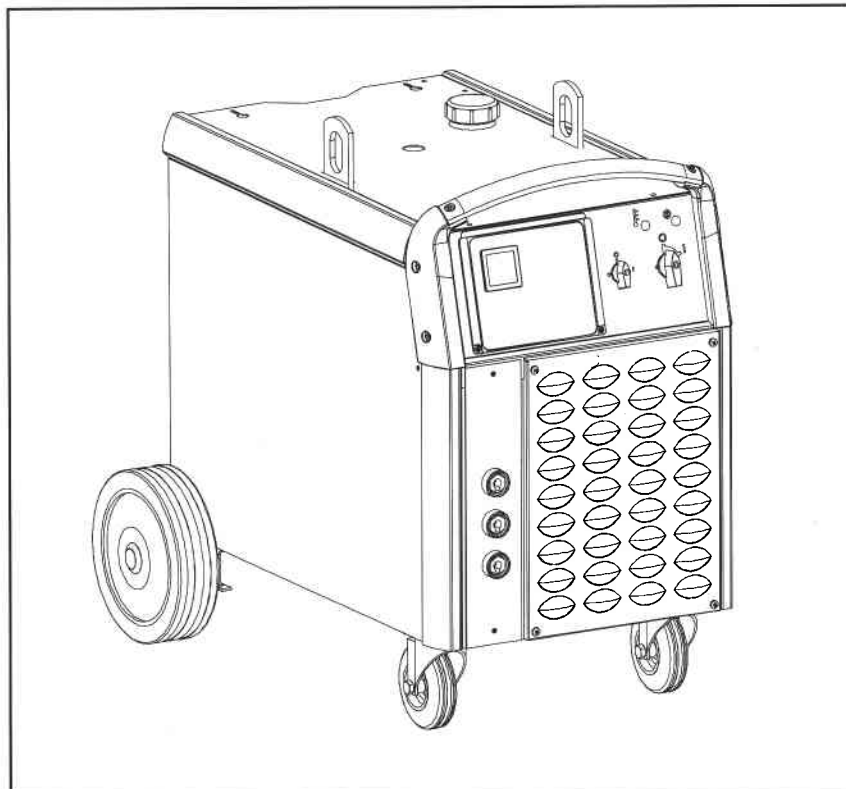

# Operating Manual

## Transmig 423S/423SW/523S/523SW



**Please ensure that this  
Instruction Manual and Parts List  
is made available to the user of  
the equipment**



# DECLARATION OF CONFORMITY

## Murex Welding Products Ltd.

Declare hereby that:

**Murex Transmig 423S/423SW/523S/523SW Power Source**

Part no. 1416126/1416128/1416130/1416134

- conform with the requirements of Council Directive 72/23/EEC, amended by Council Directive 93/68/EEC, relating to electrical equipment designed for use within certain voltage limits.
- conform with the requirements of Council Directive 89/336/EEC, amended by Council Directive 93/68/EEC, relating to electromagnetic compatibility.
- are manufactured in accordance with EN60974-1 Safety Requirements for Arc Welding Equipment.
- are manufactured in accordance with EN50199 Electromagnetic Compatibility for Arc Welding Equipment.

On behalf of Murex Welding Products Ltd.  
Hertford Road  
Waltham Cross  
Herts. EN8 7RP  
England

A handwritten signature in black ink, appearing to read "P.G. Dodd".

P.G. Dodd  
Managing Director  
ESAB Group (UK) Ltd  
March 2003

Manufactured by Esab Welding Equipment AB.



---

## Contents

	Page
• <b>Declarations of Conformity</b> .....	2
• <b>Warning</b> .....	4
• <b>Introduction</b> .....	6
• <b>Specification Transmig 423S/423SW</b> .....	6
• <b>Specification Transmig 523S/523SW</b> .....	7
• <b>Installation</b> .....	8
• <b>Assembly of Components</b> .....	9
• <b>Operation</b> .....	10
• <b>Maintenance</b> .....	11
• <b>Circuit Diagram</b> .....	12
• <b>Parts Lists</b> .....	14



## WARNING



This welding equipment has been designed, manufactured and tested to the highest standards to ensure long and trouble free life. However, regular maintenance is an essential part of keeping the machine operating in a reliable and safe manner and your attention is drawn to any maintenance instructions that are contained in this manual.

In general, all welding equipment should be thoroughly inspected, tested and serviced at least annually. More frequent checking will be required when the equipment is heavily used.

Wear and tear, particularly in electro-mechanical and moving components, are gradual processes. Caught in time, repair costs are small and the benefits in performance, reliability and safety are significant. Left alone, they can put the equipment, and you, at risk.

Have this equipment regularly inspected and maintained by an approved service centre.



## WARNING



**ARC WELDING AND CUTTING CAN BE INJURIOUS TO YOURSELF AND OTHERS. TAKE PRECAUTIONS WHEN WELDING. ASK FOR YOUR EMPLOYER'S SAFETY PRACTICES WHICH SHOULD BE BASED ON MANUFACTURERS' HAZARD DATA.**

### **ELECTRIC SHOCK – Can Kill**

- Install and earth the welding unit in accordance with applicable standards.
- Do not touch live electrical parts or electrodes with bare skin, wet gloves, or wet clothing.
- Insulate yourself from earth and work.
- Ensure your working position is secure.

### **FUMES AND GASES – Can be Dangerous to Health**

- Keep your head out of the fumes.
- Use ventilation, extraction at the arc, or both, to keep fumes and gases from your breathing zone and the general area.

### **ARC RAYS – Can Injure Eyes and Burn Skin**

- Protect your eyes and body. Use the correct welding screen and filter lens and wear protective clothing.
- Protect bystanders with suitable screens or curtains.

### **NOISE – Excessive noise can damage hearing**

- Protect your ears. Use ear defenders or other hearing protection.
- Warn bystanders of the risks.

**READ AND UNDERSTAND THE INSTRUCTION MANUAL  
BEFORE INSTALLING OR OPERATING AND SEE WMA PUBLICATION 237  
'The arc welder at work' AVAILABLE FROM THE MANUFACTURER.**

**PROTECT YOURSELF AND OTHERS**

## SAFETY

In any arc welding or gouging operation, it is the responsibility of the user to observe certain safety rules to ensure his personal safety and to protect those working near him.









Read all safety articles relevant to arc welding published by the WMA. Pay particular attention to any CAUTION or WARNING Notes included in this manual. CAUTION indicates possible equipment damage. WARNING indicates possible hazard to life.

### **WARNING**



*The ON/OFF switch on this equipment does not isolate the unit from the mains electrical supply. **AC POWER IS PRESENT ON THE ON/OFF SWITCH TERMINALS.***

*The On/Off lamp is an indication that the supply is switched on and does not imply that the unit is isolated from the supply. **BEFORE REMOVING THE COVERS FOR MAINTENANCE, ISOLATE THE UNIT FROM THE MAINS ELECTRICAL SUPPLY.***



## 1 Electrical

-  Treat electricity with respect. Even the open circuit voltage of this equipment can be dangerous. Adjustments to the torch or replacement of torch parts should be undertaken with the mains supply isolated from the unit.  
If damaged torch cables or torch components are found, the unit must be disconnected from the mains and defective parts must be replaced using only Murex spare parts.
-  Do not work on live circuits or cables. Disconnect the main power supply before checking the machine or performing any maintenance operation.
-  Be sure the case of the welding machine is properly connected to a good electrical earth.
-  Have the wiring for the welding machine installed by a qualified electrician. All connections must be made according to specifications in force and to general safety standards.
-  Do not stand in water or on damp floors while using an arc welder or cutter. Do not use in the rain.
-  Do not operate with worn or poorly connected cables. Inspect all cables frequently for insulation failure, exposed wires and loose connections.
-  Do not overload cables or continue to operate with overheating cables. Cables which are too small for the current carried will overheat, causing rapid deterioration of the insulation.
-  Pay attention that live parts of the torch do not touch any metal which is connected to the earth cable. Fix an insulated hook to hang the torch on when it is not in use.





## 2 Ventilation

-  Do not weld or cut on containers which have held combustible or flammable materials, or materials which give off flammable or toxic vapours when heated, without proper cleaning.
-  Locate the welding/cutting operation far enough from any vapour-type degreaser using trichlorethylene or other chlorinated hydrocarbons as solvents. The ultraviolet light from the arc can decompose these vapours into toxic gases at a considerable distance from the arc, even though the concentration of the gases is low enough to be undetectable by smell.
-  Be sure to provide adequate ventilation for removal and dilution of fume and gases. Fume exhaust facilities near the arc, or a ventilated helmet should be used when cutting in confined spaces or on toxic material.



## 3 Glare

-  Never look at the arc without wearing eye protection.  
Always use the proper protective clothing, filter glasses, and gloves. Be careful to avoid exposed skin areas. Do not use cracked or defective helmets or shields.
-  Never strike an arc when there is someone near who is not protected from the strong light of the arc.
-  Warn bystanders who are not aware of the dangers of ultra-violet light.



## 4 General

-  Take care when lifting the unit.
-  Ensure that cylinders are secured by chains.
-  Locate the unit so that there is adequate air flow to the ventilation louvres.
-  Always dress correctly to protect against glare, radiation and spatter.

## 5 Fire

-  Ensure that the correct type of fire extinguisher is available in the welding area.
-  Do not weld near flammable materials or liquids, in or near explosive atmospheres, or on pipes carrying explosive gases.

## 6 Vehicle Electrics

-  When working on motor vehicles, remove the battery and any circuitry which may be damaged by the arc.
-  Whilst welding be aware of the possibility of 'hidden wires' behind panels or bulkheads.

## 7 Moving Parts

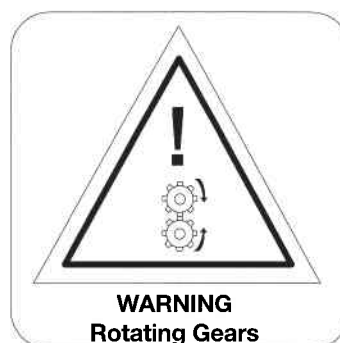

Switch off before accessing areas which contain moving parts. Particular care should be taken when accessing the wire feed mechanism.

## INTRODUCTION

Murex Transmig 423S/423SW/523S/523SW are industrial 3 phase electronic thyristor-controlled flat characteristic power sources for MIG/MAG welding with solid or cored wires. They are normally used together with a Murex Transmatic Lynx 4 EHD or Suitcase wire feed unit for dip-through spray transfer processes. Transmig 423SW/523SW incorporates a MIG torch water-cooling unit.

## Specification Transmig 423S/423SW

### Standard delivery:

Power source. (Transmig 423SW includes inbuilt torch water-cooler).

Mains cable 3m (fitted).

Includes: Gas cylinder shelf (fitted with 2 screws).

Mounting post for wire feed unit. Work return lead.

Specification	Transmig 423S/SW
<b>Voltage</b>	400-415V, 3-50Hz
<b>Permissible load at</b>	
100% duty cycle	280A/28V
60% duty cycle	350A/32V
45% duty cycle	400A/34V
<b>Setting range (DC)</b>	50A/16V-420A/34V
<b>Open circuit voltage</b>	53-58V
<b>Open circuit power</b>	590/790W
<b>Efficiency</b>	0.74
<b>Power factor</b>	0.86
<b>Control voltage</b>	42V, 50/60Hz
<b>Enclosure class</b>	IP23
<b>Weight</b>	209/223kg
<b>Dimensions lxbxh</b>	800x640x835mm
<b>Application classification</b>	<input type="checkbox"/> S

## Specification Transmig 523S/523SW

### Standard delivery:

Power source. (Transmig 523SW includes inbuilt torch water-cooler).

Mains cable 3m (fitted).

Includes: Gas cylinder shelf (fitted with 2 screws).

Mounting post for wire feed unit. Work return lead.

Specification	Transmig 523S/SW
<b>Voltage</b>	400-415V, 3-50Hz
<b>Permissible load at</b>	
100% duty cycle	400A/34V
80% duty cycle	450A/37V
60% duty cycle	500A/39V
<b>Setting range (DC)</b>	50A/16.5V-520A/39V
<b>Open circuit voltage</b>	53-60V
<b>Open circuit power</b>	670/870W
<b>Efficiency</b>	0.78
<b>Power factor</b>	0.90
<b>Control voltage</b>	42V, 50/60Hz
<b>Enclosure class</b>	IP23
<b>Weight</b>	235/249kg
<b>Dimensions lxbxh</b>	800x640x835mm
<b>Application classification</b>	<span style="border: 1px solid black; padding: 0 2px;">S</span>

Cooling unit	
Cooling power	2500W at 40°C temp. difference and flow 1.5 l/min
Coolant	50% water/50% glygol
Coolant quantity	5.5 l
Maximum water flow	2 l/min

### Duty cycle

The duty cycle refers to the time as a percentage of a ten-minute period that you can weld at a certain load without overloading.

### Enclosure class

The **IP** code indicates the enclosure class, ie. the degree of protection against penetration by solid objects or water. Equipment marked **IP23** is designed for indoor and outdoor use.

### Application class

The symbol S indicates that the power source is designed for use in areas with increased electrical hazard.

## INSTALLATION

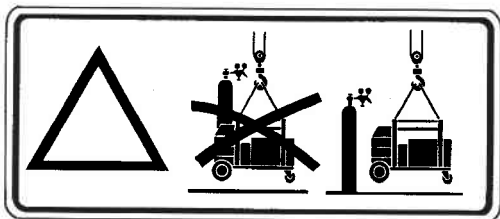

### Important

- Electrical installation must be carried out by a qualified electrician.
- Site the unit so that the ventilation grilles are clear of obstructions.
- Ensure all flammable materials are removed from the area.
- Ensure the gas cylinder retaining chain is installed when mounting the gas cylinder.
- This product is for industrial use. In a domestic environment it may cause electromagnetic interference.
- Check that the primary cable is of the correct cross-section for the mains supply.
- The front panel on/off switch does not isolate the mains electrical supply.

### Mains supply Transmig 423S/423SW

	3-50Hz
<b>Voltage</b>	400/415V
<b>Current 100%</b>	23A
<b>60%</b>	28A
<b>45%</b>	31A
<b>Mains lead</b>	4x4mm <sup>2</sup>
<b>Fuse, slow</b>	25A

### Mains supply Transmig 523S/523SW

	3-50Hz
<b>Voltage</b>	400/415V
<b>Current 100%</b>	35A
<b>60%</b>	39A
<b>45%</b>	41A
<b>Mains lead</b>	4x6mm <sup>2</sup>
<b>Fuse, slow</b>	35A



## Assembly of components

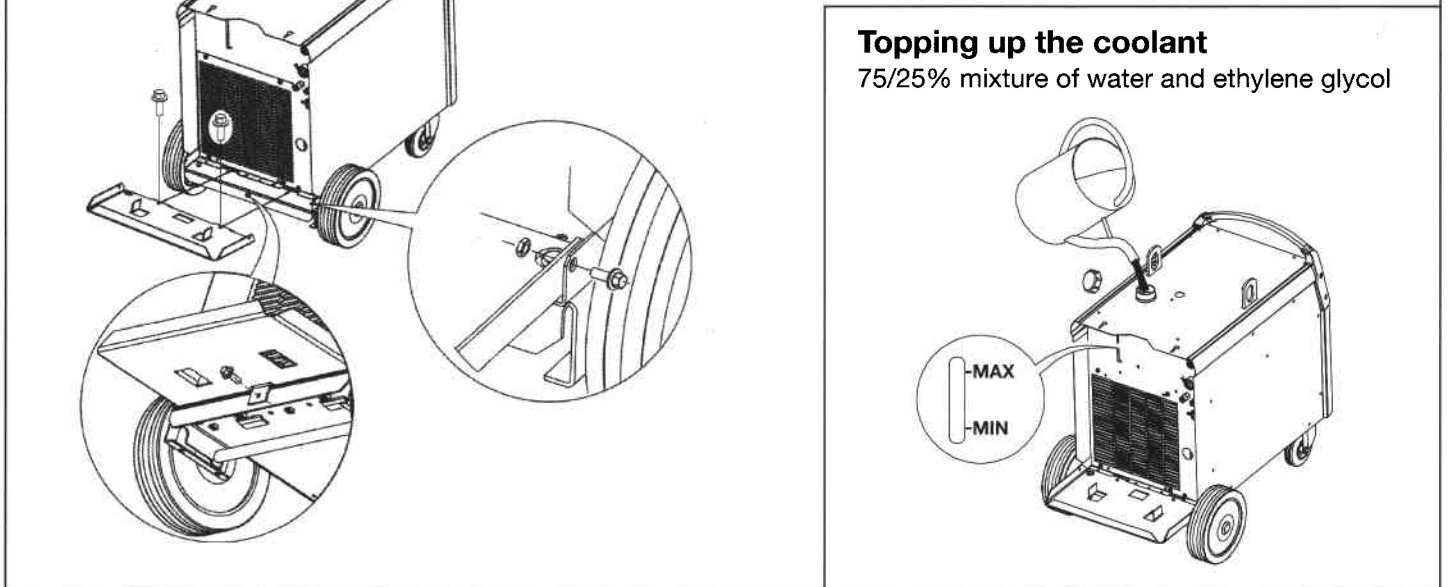
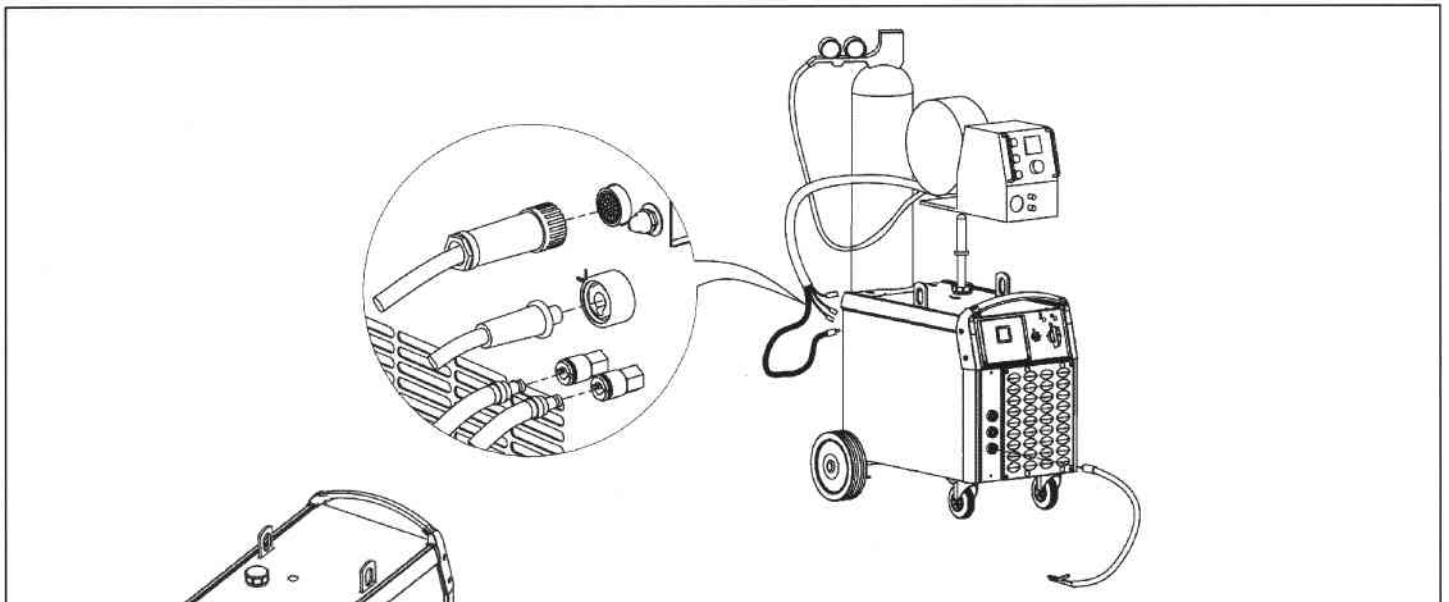
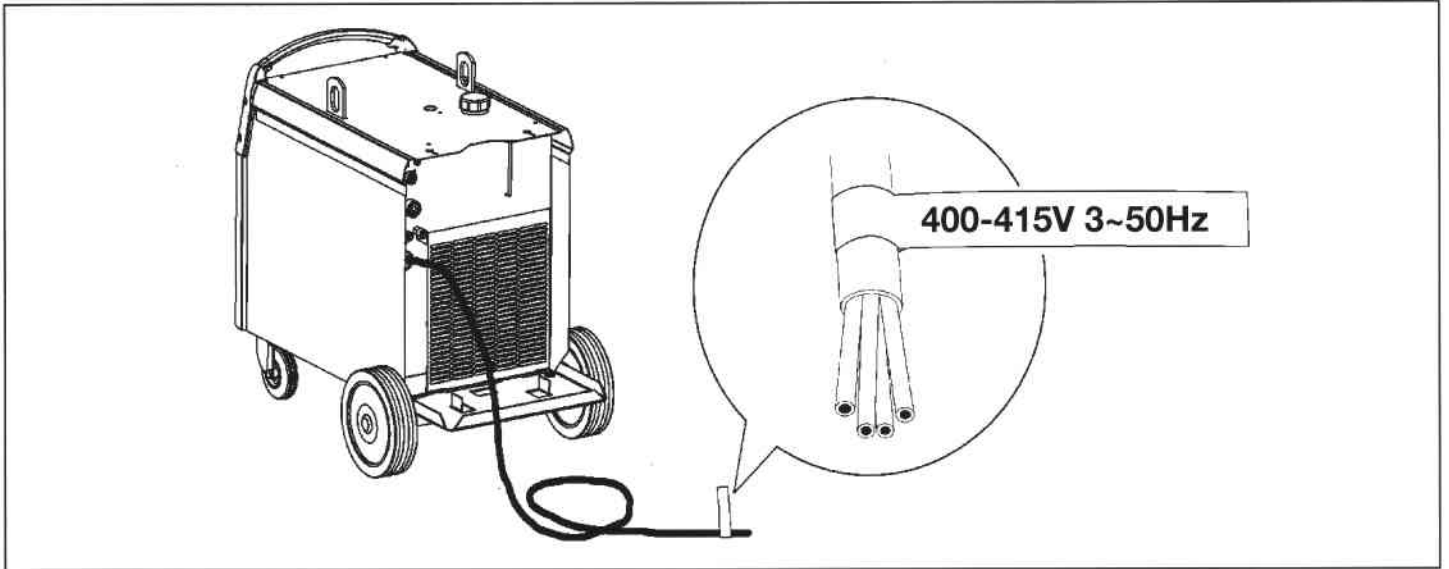

## OPERATION

Transmig 423S/423SW/523S/523SW utilise thyristor-control providing electronic-controlled continuous/adjustment of welding voltage. In addition 3 different inductance levels can be selected at the - ve welding outlets (normally the work connection) on the lower front panel.

The machines are fan-cooled (2 speed thermostatic) and incorporate thermal overload protection. If the machine is overheated the orange warning light will illuminate and welding output will stop. In this event leave the machine switched on with the fan running, resetting is automatic when the unit has cooled.

- |  |   |
|--|---|
| 1 Connection for control cable to the wire feed unit | 9 Connection for return cable (-), medium inductance        |
| 2 10A circuit breaker                                | 10 Connection for return cable (-), high inductance         |
| 3 Display (digital meters)                           | 11 Connection RED for cooling water from the wire feed unit |
| 4 Orange indicating lamp, overheating                | 12 Connection BLUE for cooling water to the wire feed unit  |
| 5 White indicating lamp, power supply ON             | 13 Connection for welding current cable (+)                 |
| 6 Main supply switch                                 |   |
| 7 Main supply switch for cooling unit                |   |
| 8 Connection for return cable (-), low inductance    |   |

**NOTE!** Cooling water connections only available on certain models.

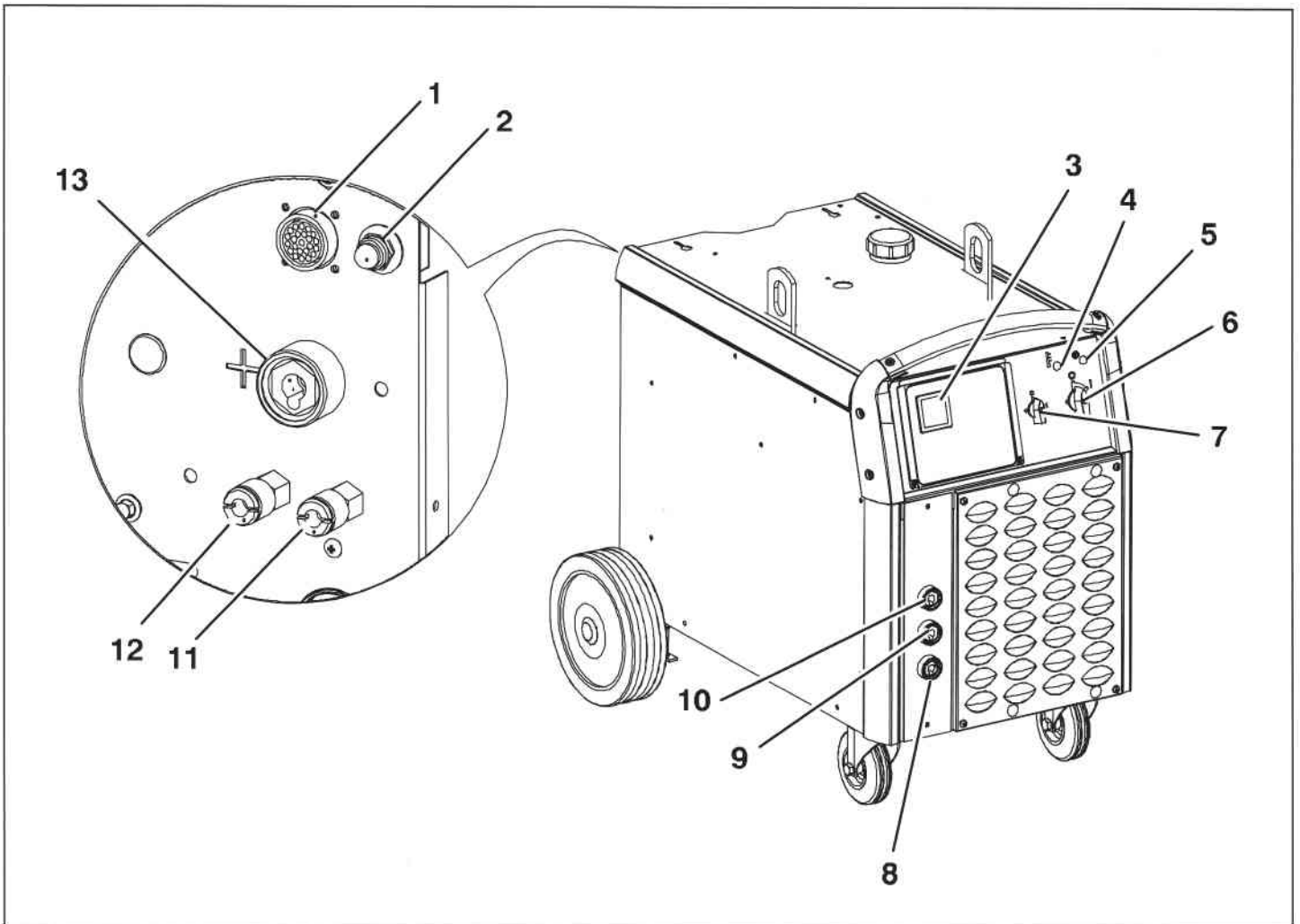

## MAINTENANCE

- Regular maintenance is important for reliable and safe operation.
  
- **Daily**
  - Check all welding and electrical connections and cables for signs of deterioration
  - Check the gas supply, hoses and connectors
  - Check the water-cooling unit ('W' versions only) and top-up if necessary
  - Check the fan is operating normally
  
- **At least annually**
  - Disconnect the machine from the mains electrical supply
  - Remove the top and side covers
  - Blow out the inside of the unit with clean, dry compressed air at low pressure
  - Check the security of all wiring, connections and components
  - Refit the covers
  
- **Annually**
  - Have an insulation and earth continuity test carried out by an approved service agent.

## ACCESSORIES

1415335	5m Interconnection to Transmatic Lynx 4EHD feeder
1415336	12m Interconnection to Transmatic Lynx 4EHD feeder
1415337	20m Interconnection to Transmatic Lynx 4EHD feeder
1403219	5m Work return lead & clamp (Transmig 423S/423SW)
1414234	8m Work return lead & clamp (Transmig 523S/523SW)
1414015	Water hose 6.6m (2 required)
368541-005	Burndy plug 23 way (excl. pins)
323945-004	Burndy pin (8 required)