

# ***Tradesmig 141***

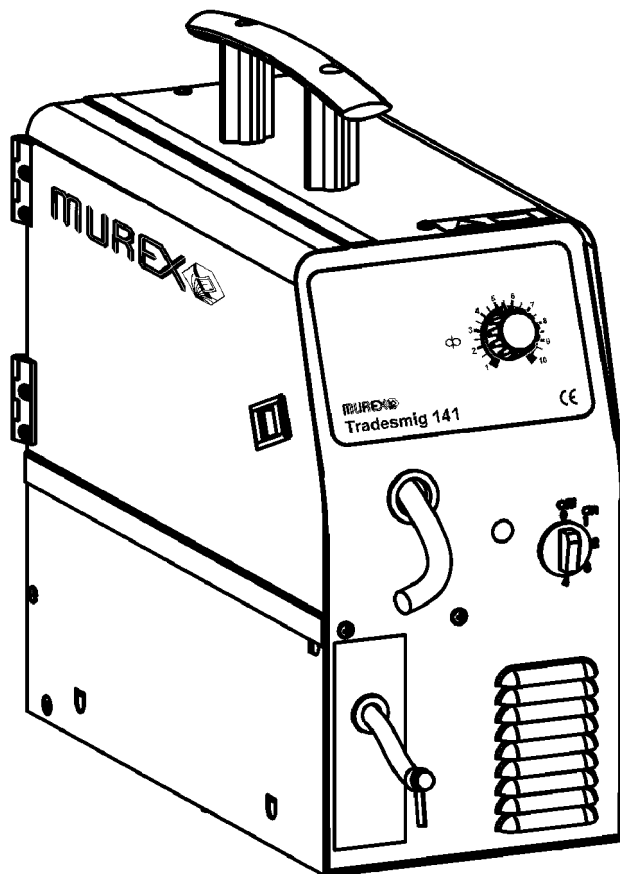

**Instruction manual**



---

# DECLARATION OF CONFORMITY

## Murex Welding Products Ltd.

Declare hereby that:

**Murex Tradesmig 141**

Part No. 0349 309 291

Manufactured after 1st May 2005

- conform with the requirements of Council Directive 72/23/EEC, amended by Council Directive 93/68/EEC, relating to electrical equipment designed for use within certain voltage limits.
- conform with the requirements of Council Directive 89/336/EEC, amended by Council Directive 93/68/EEC, relating to electromagnetic compatibility.
- are manufactured in accordance with EN60974-1 Safety Requirements for Arc Welding Equipment.
- are manufactured in accordance with EN60974-10 Electromagnetic Compatibility for Arc Welding Equipment.

On behalf of Murex Welding Products Ltd. Hanover House, Queensgate Britannia Road, Waltham Cross Herts. EN8 7TF England	
	Kent Eimbrodt Global Director Equipment and Automation

Manufactured by Esab Welding Equipment AB.

<b>1 SAFETY</b> .....	<b>4</b>
<b>2 INTRODUCTION</b> .....	<b>6</b>
2.1 Equipment .....	6
<b>3 TECHNICAL DATA</b> .....	<b>6</b>
<b>4 INSTALLATION</b> .....	<b>7</b>
4.1 Placing .....	7
4.2 Assembly of components .....	7
4.3 Electrical installation .....	8
4.4 Mains power supply .....	9
<b>5 OPERATION</b> .....	<b>9</b>
5.1 Connection and control devices .....	10
5.2 Functions explanation .....	10
<b>6 MAINTENANCE</b> .....	<b>10</b>
6.1 Inspection and cleaning .....	10
<b>7 FAULT TRACING</b> .....	<b>11</b>
<b>DIAGRAM</b> .....	<b>12</b>
<b>WEAR COMPONENTS</b> .....	<b>14</b>
<b>ACCESSORIES</b> .....	<b>15</b>

Rights reserved to alter specifications without notice.

---

# 1 SAFETY

---

Users of welding equipment have the ultimate responsibility for ensuring that anyone who works on or near the equipment observes all the relevant safety precautions. Safety precautions must meet the requirements that apply to this type of welding equipment. The following recommendations should be observed in addition to the standard regulations that apply to the workplace.

All work must be carried out by trained personnel well-acquainted with the operation of the welding equipment. Incorrect operation of the equipment may lead to hazardous situations which can result in injury to the operator and damage to the equipment.

1. Anyone who uses the welding equipment must be familiar with:
  - its operation
  - location of emergency stops
  - its function
  - relevant safety precautions
  - welding
2. The operator must ensure that:
  - no unauthorised person is stationed within the working area of the equipment when it is started up.
  - no-one is unprotected when the arc is struck
3. The workplace must:
  - be suitable for the purpose
  - be free from draughts
4. Personal safety equipment
  - Always wear recommended personal safety equipment, such as safety glasses, flame-proof clothing, safety gloves.
  - Do not wear loose-fitting items, such as scarves, bracelets, rings, etc., which could become trapped or cause burns.
5. General precautions
  - Make sure the return cable is connected securely.
  - Work on high voltage equipment **may only be carried out by a qualified electrician.**
  - Appropriate fire extinguishing equipment must be clearly marked and close at hand.
  - Lubrication and maintenance must **not** be carried out on the equipment during operation.



# WARNING



**ARC WELDING AND CUTTING CAN BE INJURIOUS TO YOURSELF AND OTHERS. TAKE PRECAUTIONS WHEN WELDING. ASK FOR YOUR EMPLOYER'S SAFETY PRACTICES WHICH SHOULD BE BASED ON MANUFACTURERS' HAZARD DATA.**

**ELECTRIC SHOCK - Can kill**

- Install and earth the welding unit in accordance with applicable standards.
- Do not touch live electrical parts or electrodes with bare skin, wet gloves or wet clothing.
- Insulate yourself from earth and the workpiece.
- Ensure your working stance is safe.

**FUMES AND GASES - Can be dangerous to health**

- Keep your head out of the fumes.
- Use ventilation, extraction at the arc, or both, to take fumes and gases away from your breathing zone and the general area.

**ARC RAYS - Can injure eyes and burn skin.**

- Protect your eyes and body. Use the correct welding screen and filter lens and wear protective clothing.
- Protect bystanders with suitable screens or curtains.

**FIRE HAZARD**

- Sparks (spatter) can cause fire. Make sure therefore that there are no inflammable materials nearby.

**NOISE - Excessive noise can damage hearing**

- Protect your ears. Use earmuffs or other hearing protection.
- Warn bystanders of the risk.

**MALFUNCTION - Call for expert assistance in the event of malfunction.**

**READ AND UNDERSTAND THE INSTRUCTION MANUAL BEFORE INSTALLING OR OPERATING.**

**PROTECT YOURSELF AND OTHERS!**

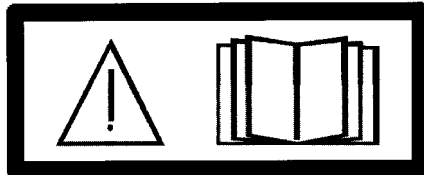

## WARNING!

Read and understand the instruction manual before installing or operating.



## WARNING!

Do not use the power source for thawing frozen pipes.



**This product is solely intended for arc welding.**

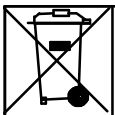

**Do not dispose of electrical equipment together with normal waste!**

In observance of European Directive 2002/96/EC on Waste Electrical and Electronic Equipment and its implementation in accordance with national law, electrical equipment that has reached the end of its life must be collected separately and returned to an environmentally compatible recycling facility. As the owner of the equipment, you should get information on approved collection systems from our local representative.

By applying this European Directive you will improve the environment and human health!

---

## 2 INTRODUCTION

---

**Tradesmig 141** are step controlled power sources in a compact design, intended for welding with solid steel, stainless steel or aluminium wire as well as tubular wire with or without shielding gas. The possibility of welding with homogeneous wire/shielding gas and welding with gasless tubular wire is obtained by switching the + and - connections on the switching terminal by the wire feed unit.

**ESAB's accessories for the product can be found on page 15.**

### 2.1 Equipment

The power source is supplied with:

- Welding gun
- Return cable with return clamp
- Instruction manual

---

## 3 TECHNICAL DATA

---

	<b>Tradesmig 141</b>
<b>Voltage</b>	230-240V, 1~ 50/60Hz
<b>Permissible load at 100% duty cycle</b>	42A/16,1V
60 % duty cycle	54A/16,7V
20 % duty cycle	100A/17,0V
<b>Setting range (DC)</b>	35A/15,7V-83A/18,2V (130A/13,4)
<b>Open circuit voltage</b>	18,7-25,1V
<b>Open circuit power</b>	75W
<b>Power factor</b> at max load	0,91
<b>Control voltage</b>	230-240V, 50/60Hz
<b>Wire feed speed</b>	2,0-14m/min
<b>Welding gun connection</b>	fixed
<b>Wire dimension range</b>	0,6-0,8(Fe) 1,0 (Al) 0,8(cored) 0,8(CuSi)
<b>Max diameter/weight of wire bobin</b>	200mm/5kg
<b>Dimensions l x w x h</b>	650x300x550
<b>Weight</b>	25kg
<b>Operating temperature</b>	-10 ÷ +40°C
<b>Enclosure class</b>	IP 23
<b>Application classification</b>	<b>S</b>

#### Duty cycle

The duty cycle refers to the time as a percentage of a ten-minute period that you can weld at a certain load without overloading.

### Enclosure class

The IP code indicates the enclosure class, i. e. the degree of protection against penetration by solid objects or water. Equipment marked IP23 is designed for indoor and outdoor use.

### Application class

The symbol **S** indicates that the power source is designed for use in areas with increased electrical hazard.

---

## 4 INSTALLATION

---

*The installation must be executed by a professional.*

### 4.1 Placing

Position the welding power source such way that its cooling air inlets and outlets are not obstructed.

### 4.2 Assembly of components

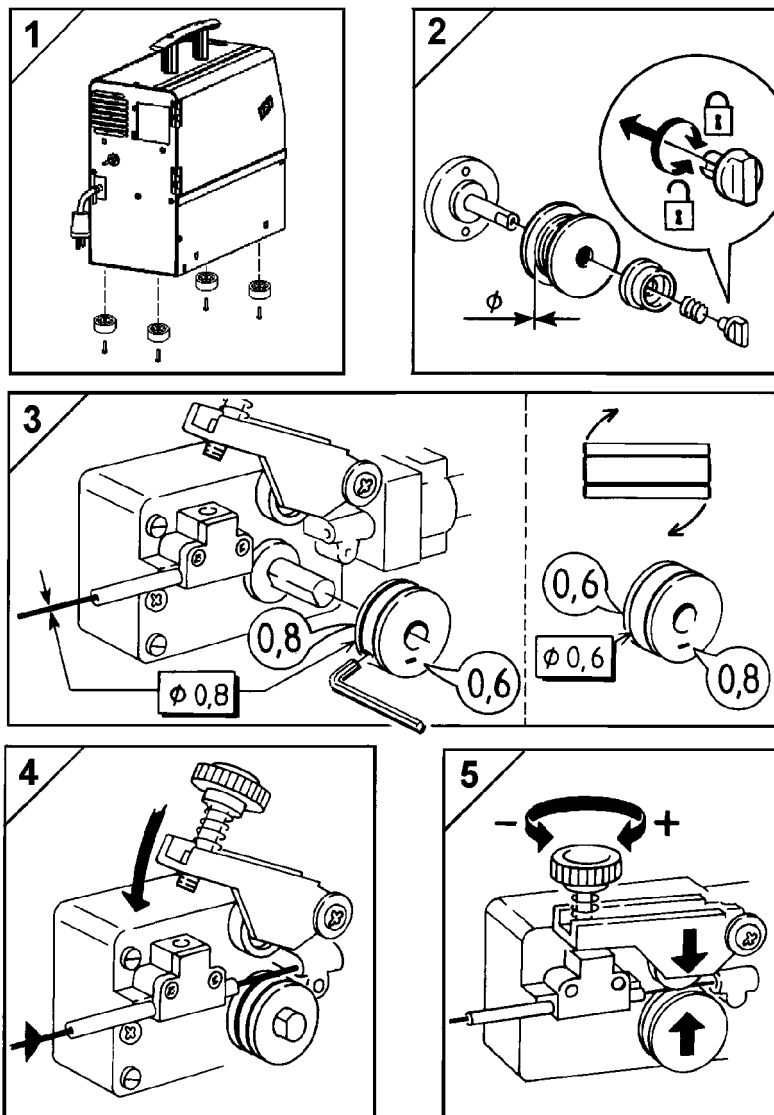

4.3 Electrical installation

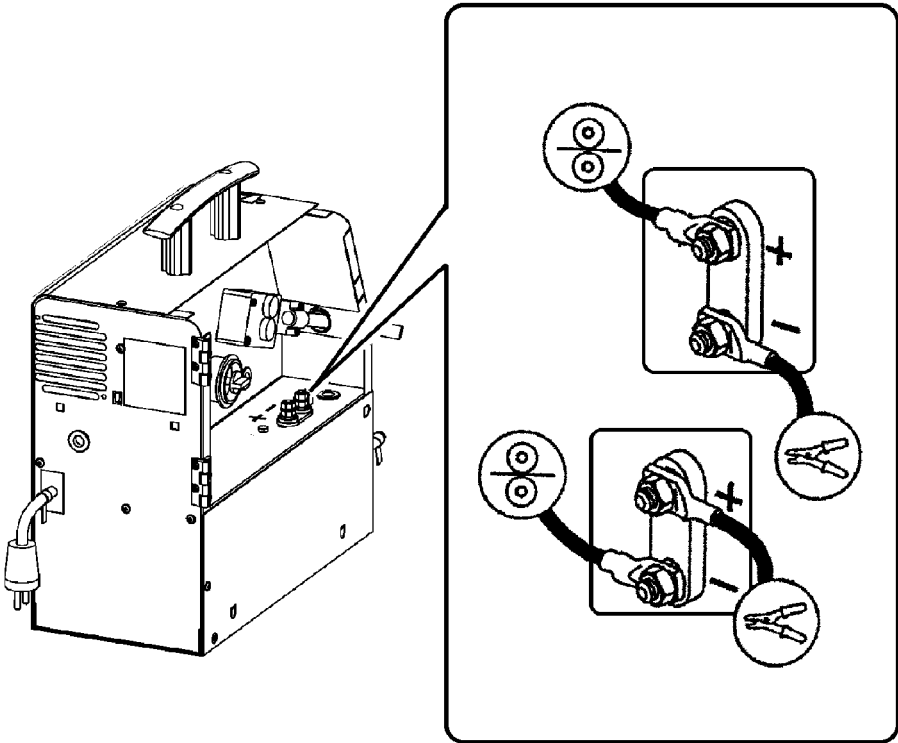
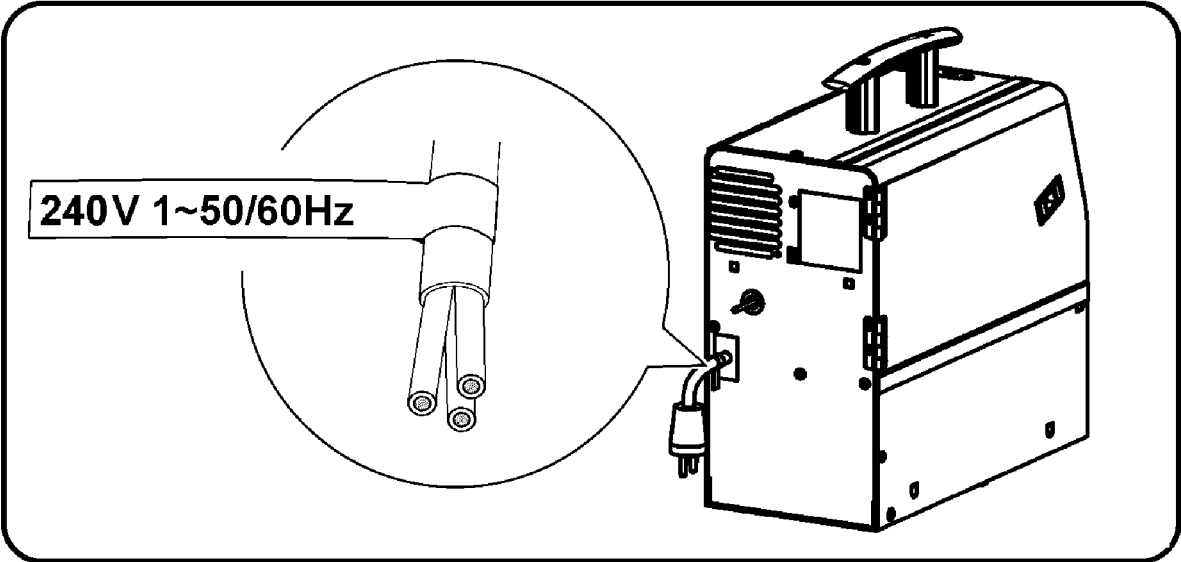



## 4.4 Mains power supply

Check that the unit is connected to the correct mains power supply voltage, and that it is protected by the correct fuse size. A protective earth connection must be made, in accordance with regulations.

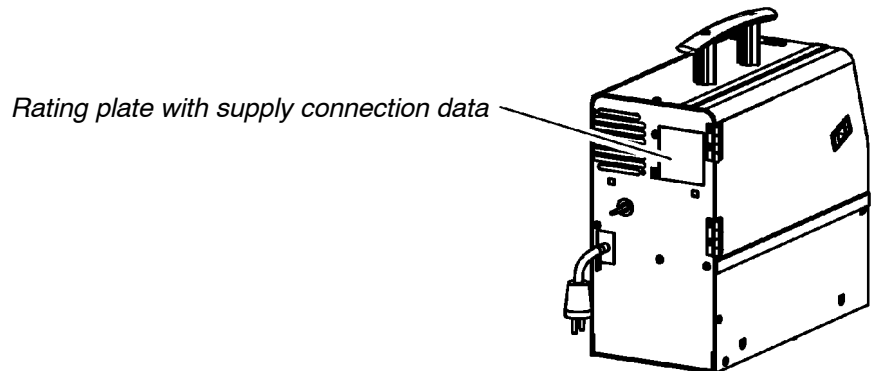



	Tradesmig 141
<b>Voltage V</b>	230–240V, 1~ 50/60Hz
<b>Current A</b> at 100% duty cycle	5,1
at 60% duty cycle	7,0
at 20% duty cycle	13,8
<b>Cable area mm<sup>2</sup></b>	3 x 1.5
<b>Fuse slow A</b>	10

**NB:** The mains cable areas and fuse sizes as shown above are in accordance with Swedish regulations. They may not be applicable in other countries: make sure that the cable area and fuse sizes comply with the relevant national regulations.

## 5 OPERATION

**General safety regulations for the handling of the equipment can be found on page 4. Read through before you start using the equipment!**

	<b>WARNING!</b> Rotating parts can cause injury, take great care.	
---	--	---

	<b>WARNING - TIPPING RISK!</b> There is a risk of tipping while transportation and operation, if the welding machine leans more than 10°. In that case appropriate securing has to be provided !
---	---

## 5.1 Connection and control devices

- |   |  |   |                                |
|---|--|---|--------------------------------|
| 1 | Welding voltage switch<br>OFF + 4 steps (mains ON/OFF) | 4 | Return cable with clamp, fixed |
| 2 | Orange indicating lamp, overheating                    | 5 | Knob for wire speed setting    |
| 3 | Welding gun, fixed                                     |   |                                |

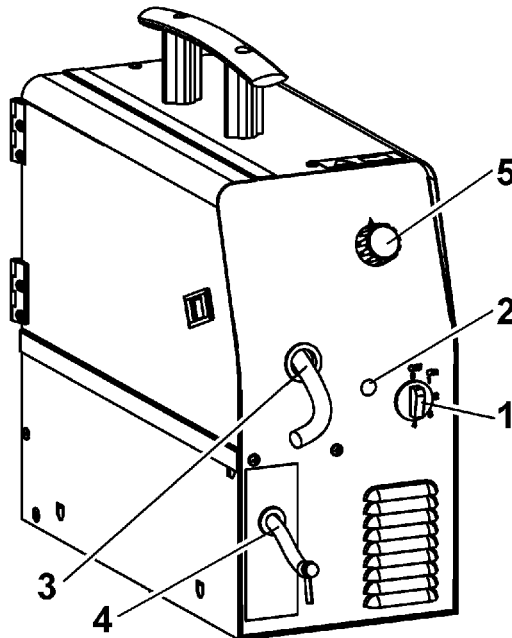

## 5.2 Functions explanation

### 5.2.1 Overheating protection

If the internal temperature becomes too high, the welding is interrupted and disabled. This state is indicated by lighting of the orange indicating lamp [2] on the front of the machine. It resets automatically when the temperature has fallen.

---

## 6 MAINTENANCE

---

*Regular maintenance is important for safe, reliable operation.*

### **Note!**

*All guarantee undertakings from the supplier cease to apply if the customer himself attempts any work in the product during the guarantee period in order to rectify any faults.*

## 6.1 Inspection and cleaning

Check regularly that the power source is free from dirt.

The power source should be regularly blown clean using dry compressed air at reduced pressure. More frequently in dirty environments. Otherwise the air inlet/outlet may become blocked and cause overheating.

## Welding gun

- Cleaning and replacement of the welding gun's wear parts should take place at regular intervals in order to achieve trouble-free wire feed. Blow the wire guide clean regularly and clean the contact tip.

---

## 7 FAULT TRACING

---

*Try these recommended checks and inspections before sending for an authorised service technician.*

Type of fault	Actions
No arc	<ul style="list-style-type: none"><li>• Check that the mains power supply switch is turned on.</li><li>• Check that the welding current supply and return cables are correctly connected.</li><li>• Check that correct current value is set.</li></ul>
Welding current is interrupted during welding	<ul style="list-style-type: none"><li>• Check whether the thermal overload trip has operated (indicated by the orange lamp on the front).</li><li>• Check the main power supply fuses.</li></ul>
Thermal overload trips operate frequently	<ul style="list-style-type: none"><li>• Check to see whether the air inlets/outlets are clogged.</li><li>• Make sure that you are not exceeding the rated data for the power source (i.e. that the unit is not being overloaded).</li></ul>
Poor welding performance	<ul style="list-style-type: none"><li>• Check that the welding current supply and return cables are correctly connected.</li><li>• Check that the correct current value is set.</li><li>• Check that the correct welding wires are being used.</li><li>• Check the main power supply fuses.</li><li>• Check the wire feed unit – if proper rolls are applied and properly set the pressure of the wire feeder's pressure rollers</li></ul>

**Tradesmig 141 is designed and tested in accordance with the international and European standards IEC/EN 60974-1 and EN 60974-10. It is the obligation of the service unit which has carried out the service or repair work to make sure that the product still conforms to the said standard.**

# Diagram

## Tradesmig 141

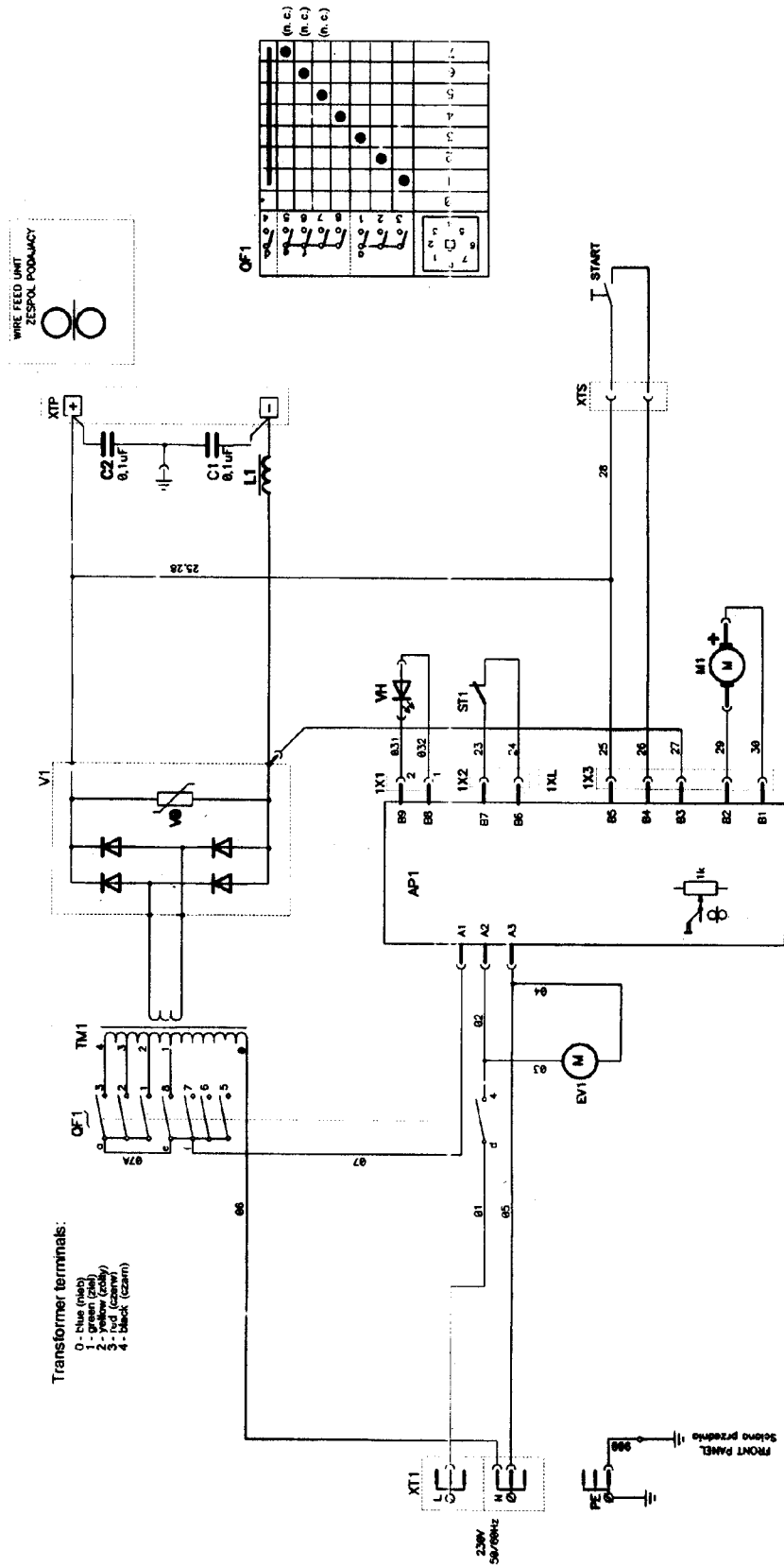

## Tradesmig 141

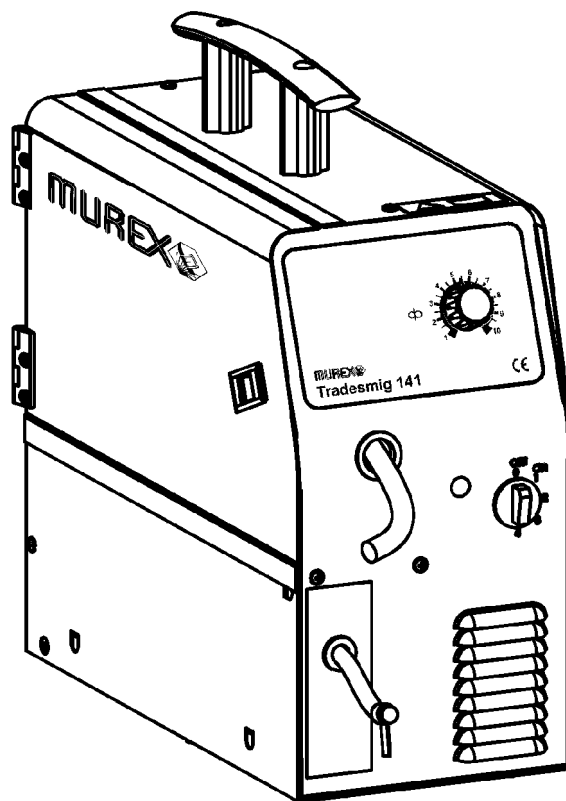

Valid for serial no. 811-XXX-XXXX

### Ordering numbers

0349 311 670 Tradesmig 141

230-240V 1~50/60Hz

**Wear components**

**(W. F. Mechanism 0469 475 880)**

Item	Denomination	Ordering no.	Notes
A	Feed roller	0469 517 001 0349 311 443	Ø 0.6–0.8mm Fe, cored wire, CuSi Ø 1.0mm Al
B	Liner	0700 200 099 0349 311 441	Fe, cored wire, CuSi Al
C	Contact tip	0700 200 063 0700 200 064 0349 311 442	Ø 0.6mm Fe Ø 0.8mm Fe, cored wire, CuSi Ø 1.0mm Al

The rollers are marked with wire dimension in mm, some are also marked with inch.

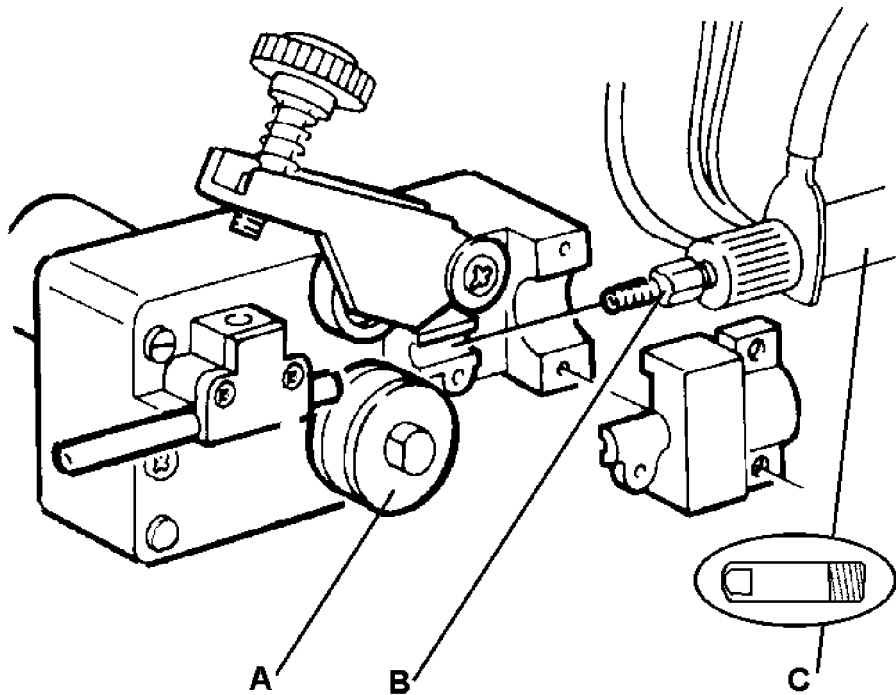

**Welding with aluminium wires.**

In order to weld with aluminium wires, proper rollers, nozzles and liners for aluminium wires **MUST** be used. It is recommended to use 3m long welding gun for aluminium wires, equipped with appropriate wear parts.

**Accessories**

